

**Troubleshooting**

The troubleshooting manual is valid for the following heater:

**B 2 L – 12 V** Control  
 20 1607 01 00 00 On – Off  
 20 1609 01 00 00 High – Low  
 20 1634 01 00 00 On – Off  
 20 1661 01 00 00 On – Off  
 20 1671 01 00 00 On – Off

**D 2 L – 12 V** Control  
 25 1507 01 00 00 On – Off  
 25 1534 01 00 00 On – Off  
 25 1597 01 00 00 Full – 1/4  
 25 1632 01 00 00 Full – 1/4  
 25 1684 01 00 00 Full – 1/4  
 25 1690 01 00 00 Full – 1/4

**B 2 L-S – 12 V** Control  
 20 1627 01 00 00 On – Off  
 20 1633 01 00 00 On – Off

**D 2 L-S – 12 V** Control  
 25 1529 01 00 00 On – Off  
 25 1541 01 00 00 On – Off

**UNCONTROLLED  
 COPY**

CHECK ISSUE STATUS PRIOR TO USE

DATE: **20 OCT 1994**

Contents	Page	Page	
Which heater model has been installed? .....	2	Repair instructions .....	18
Table: heaters in WESTFALIA vehicles / POST vehicles/VW-Factory-fitted .....	2	Removing the outer casing .....	19
Making a test cable.....	3	Removing and installing the printed circuit board.....	19
Check before troubleshooting/check values.....	3	Removing and installing the ignition spark generator.....	19
Troubleshooting.....	4-7	Removing and installing the heating coil switch.....	20
<b>Wiring diagrams</b>		Removing and installing the temperatur switch .....	20
B 2 L 20 1609 01 .....	8	Removing and installing the safety thermal cutout switch.....	20
B 2 L 20 1634 01 } without heating .....	9	Removing and installing the electric motor .....	21
B 2 L-S 20 1633 01 } coil switch .....	9	Removing and installing the blower.....	22
B 2 L 20 1634 01 } with heating .....	10	Removing and installing the heat exchanger with combustion chamber .....	23
B 2 L-S 20 1633 01 } coil switch .....	10	Assembling the heater.....	23
B 2 L 20 1661 01 .....	11	Measuring the fuel quantity.....	24
B 2 L 20 1671 01 .....	12		
D 2 L 25 1534 01 } .....	13		
D 2 L-S 25 1541 01 } .....	13		
D 2 L 25 1597 01 .....	14		
D 2 L 25 1632 01 .....	15		
D 2 L 25 1684 01 .....	16		
D 2 L 25 1690 01 .....	17		

## Which heater model has been installed?

The rating plate on the heater indicates the heater version and model installed.

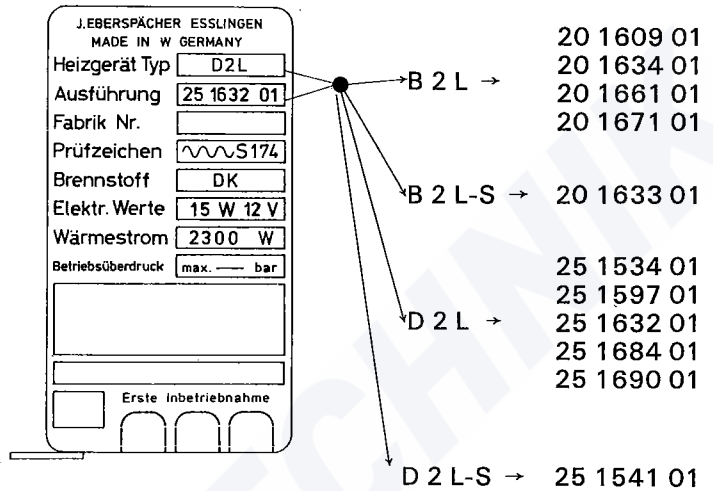
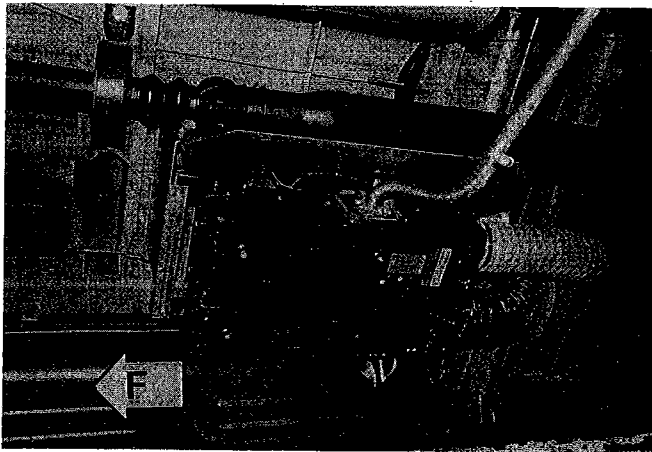

**Table: Heaters in WESTFALIA vehicles/POST vehicles/VW Factory-fitted**

Vehicle model	Fuel	from	year	to	Heater model	Version
JOKER and MOSAIK retrofit kit	petrol	1. 79		12. 80	B 2 L	20 1609 01 00 00
	petrol	1. 81		7. 84	B 2 L	20 1634 01 00 00
	petrol	8. 84		—	B 2 L	20 1661 01 00 00
	diesel	12. 80		7. 84	D 2 L	25 1534 01 00 00
	diesel	8. 84		3. 88	D 2 L	25 1597 01 00 00
	diesel	4. 88		—	D 2 L	25 1690 01 00 00
SVEN HEDIN and JAMES COOK	petrol	8. 80		12. 82	B 2 L-S	20 1633 01 00 00
	petrol	1. 83		7. 84	B 2 L	20 1634 01 00 00
	petrol	8. 84		—	B 2 L	20 1661 01 00 00
	diesel	8. 80		12. 82	D 2 L-S	25 1541 01 00 00
	diesel	1. 83		7. 84	D 2 L	25 1534 01 00 00
	diesel	8. 84		3. 88	D 2 L	25 1597 01 00 00
MARCO POLO	petrol	5. 84		—	B 2 L	20 1661 01 00 00
	diesel	5. 84		3. 88	D 2 L	25 1597 01 00 00
	diesel	4. 88		—	D 2 L	25 1690 01 00 00
POST vehicles VW bus Type 2 – Model 25	petrol	1. 82		7. 84	B 2 L	20 1634 01 00 00
	petrol	8. 84		—	B 2 L	20 1661 01 00 00
	diesel	1. 82		7. 84	D 2 L	25 1534 01 00 00
	diesel	8. 84		3. 88	D 2 L	25 1597 01 00 00
	diesel	4. 88		—	D 2 L	25 1690 01 00 00
VW Factory-fitted						
VW bus Type 2 – Model 25	petrol	—		—	B 2 L	20 1671 01 00 00
	diesel	—		—	D 2 L	25 1684 01 00 00

WESTFALIA, WEINSBERG, VOLL are companies fitting out POST vehicles.

The heater installations differ in their hot air guidance systems and controls depending on the equipper and heater model.

### Check before troubleshooting:

The troubleshooting chart omits the following faults, which must be checked as a general principle beforehand:

1. Faulty wiring (short-circuit, break)
2. Corroded contacts/no earth connection
3. Battery voltage less than 10 V  
In the glow phase, measure the voltage at the control unit between terminals 3 and 4
4. Mechanical damage to components
5. Fuel tank empty

If no fault can be found, continue to trace it using the troubleshooting chart.

### Check values

Temperature switch delayed shutoff time  
120 to 220 secs.

Blower motor speed at rated voltage (measured after switching off the glow plug):

B 2 L / D 2 L = 2 900 to 3 300 rpm

B 2 L-S / D 2 L-S = 3 600 to 4 100 rpm

### Making a test cable

With a test cable, it can be quickly ascertained whether the cause of a fault lies in the heater including control unit, and fuel supply system or in the operating and regulation system.

When this has been ensured, remove the test cable, reconnect the control system and continue the search for the fault there (test steps 2).

The test cable should be 1.5 m long.

To do so, connect the test cable to the 8 or 10 pin plug instead of to the operating system and check that the heater is functioning correctly using the troubleshooting chart (test steps 1).

#### Test cable for heaters

##### B 2 L / B 2 L-S

20 1609 01 00 00  
20 1634 01 00 00  
20 1633 01 00 00

##### D 2 L / D 2 L-S

25 1534 01 00 00  
25 1541 01 00 00

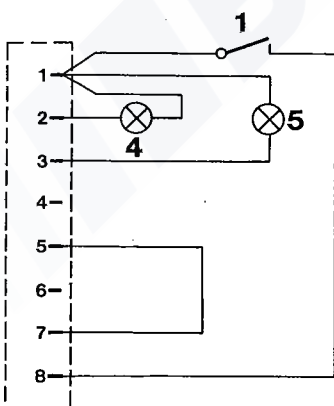

#### Test cable for heater

##### B 2 L

20 1661 01 00 00  
20 1671 01 00 00

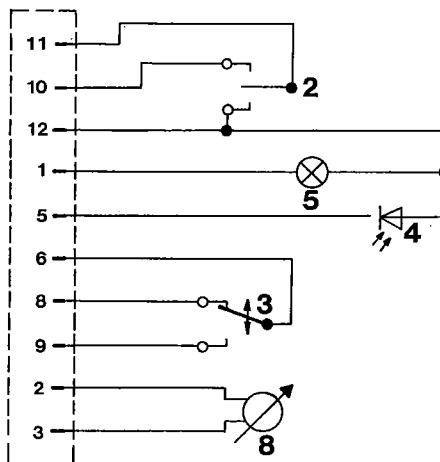

#### Test cable for heater

##### D 2 L

25 1597 01 00 00  
25 1632 01 00 00  
25 1684 01 00 00  
25 1690 01 00 00

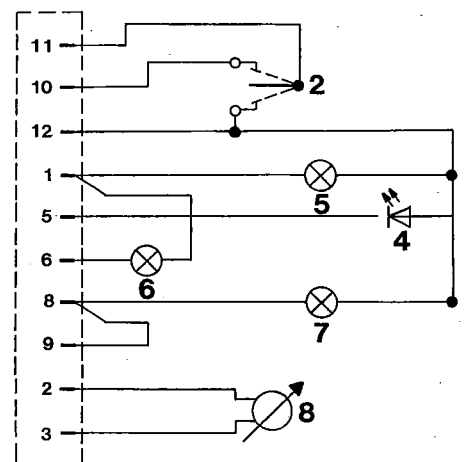

- 1 Heating switch  
2 Heating-Ventilation switch

- 3 Heating-Reventilation switch  
4 Overheat indicator

- 5 Pilot light  
6 Glow plug signal

- 7 Metering pump signal  
8 Ohmmeter for measured value 800 Ω – 1150 Ω

<b>Troubleshooting</b> <b>Fault</b> → <b>Cause</b>	No blower noise approx. 5 secs. after switching on	Blower runs for approx. 5 secs. after switching on, then cuts out automatically	Blower runs approx. 5 secs. after switching on. Pump ticks after approx. 30 secs. Automatic cutout after approx. 3 mins.	Blower runs approx. 5 secs. after switching on. Pump does not tick after approx. 30 secs. Automatic cutout after approx. 3 mins.	Heater cuts out automatically and permanently during heating operation. Red pilot light on = overheat	No reduction of heating capacity in "Low" position	Insufficient heating capacity in "High" position or heater cuts out by itself. Red pilot light not on	Heater gives off smoke and soot	Blower continues to run after switching off longer than the normal delayed cutout time of 3 - 4 mins.	Ventilation and slow reventilation functions not working	Heater does not reduce capacity  D 2 L keeps switching to low heating capacity when started. B 2 L always runs at low speed and does not generate heat
① Main fuse or motor current fuse defective	○										
Safety thermal cutout switch actuated					○						
Safety thermal cutout switch does not close (open)		○									
Glow plug in D 2 L Glow ignition plug in B 2 L coked/defective	○ D 2 L		○ B 2 L								
Heating coil switch Ignition spark generator defective (B 2 L only)			○ B 2 L								
Temperature switch does not switch cold to hot			○								
Temperature switch does not switch hot to cold								○			
Control unit not transmitting pulses for fuel metering pump				○							
Reed relay in control unit has no contact		○									
Relay in control unit sticking								○			
Fuel metering pump not working				○							
Fuel metering pump supplying too much					○		○				
Fuel metering pump supplying too little			○								
Fuel line leaking Cup strainer in metering pump clogged			○								

① check with test cable

Check	Remedy
Visual check/continuity check Main fuse: short-circuit in the wiring, heating coil coked Motor current fuse: blower damaged	Replace 16 A main fuse  Replace motor current fuse (only use EBERSPÄCHER fuse links)
Red pilot light flashing or steady after automatic cutout. Measure blower speed, Measure fuel quantity (see p. 24)	Remove blockage on intake or discharge side, replace blower (see p. 22) replace fuel metering pump switch off and back on
No negative on terminal 5 (control unit) in switched off condition	Replace safety thermal cutout switch (see p.20)
Visual check	Replace plug
<b>Heating coil switch:</b> opening temperature 45°C, closing temperature 25°C. <b>Ignition spark generator:</b> hold high-voltage cable approx. 5 mm against earth	Replace heating coil switch (see p.20) Replace ignition spark generator (see p. 19)
Heater cuts out automatically after approx. 3 minutes. No delayed cutout	Replace temperature switch (see p.20)
No continuity between terminals 1 and 8 (control unit) when heater is switched off	Replace temperature switch (see p.20)
Connect pilot light to metering pump. If there are no pulses:	Replace control unit
See under Fault	Replace control unit
Blower continues to run after switching off longer than the normal delayed cutout time of 3 - 4 minutes, furthermore voltage present at the glow plug connection	Replace control unit
Connect pilot light to the metering pump. If there are pulses:	Replace the metering pump
Measure the fuel quantity (see p. 24). If outside the permissible tolerance:	Replace the metering pump
Measure the fuel quantity (see p. 24). If outside the permissible tolerance:	Replace the metering pump
Visula check	Bleed, seal, and replace cup strainer

<b>Troubleshooting</b> <b>Fault</b> → <b>Cause</b>	No blower noise approx. 5 secs. after switching on	Blower runs for approx. 5 secs. after switching on, then cuts out automatically	Blower runs approx. 5 secs. after switching on. Pump ticks after approx. 30 secs. Automatic cutout after approx. 3 mins.	Blower runs approx. 5 secs. after switching on. Pump does not tick after approx. 30 secs. Automatic cutout after approx. 3 mins.	Heater cuts out automatically and permanently during heating operation. Red pilot light on = overheated	No reduction of heating capacity in "Low" position	Insufficient heating capacity in "High" position or heater cuts out by itself. Red pilot light not on	Heater gives off smoke and soot	Blower continues to run after switching off longer than the normal delayed cutout time of 3 - 4 mins.	Ventilation and slow reventilation functions not working	Heater does not reduce capacity  D 2 L keeps switching to low heating capacity when started. B 2 L always runs at low speed and does not generate heat
① Hot air hose damaged or dropped of							○				
Heating air line clogged (intake or discharge side)					○						
Combustion air line or exhaust line clogged								○			
Blower motor speed too low					○						
Electric motor defective	○										
Blower damage	○										
P.C.B. in heater defective. Heater versions: 20 1661/25 1597/25 1684 20 1671/25 1632/25 1690 (relay coil interrupted)	○										
Relay sticking										○	
② P.C.B. in heater defective. Heater versions: 20 1634    25 1534 20 1633    25 1541							○				
P.C.B. in heater defective. Heater version 20 1609	○										
P.C.B. in heater defective. Heater version 20 1609 (diode does not block)							○				
Control elements defective	○										
Room thermostat does not switch over or temperature switch does not switch over						○	○				
Room thermostat defective Heater versions: 20 1661/25 1597/25 1684 20 1671/25 1632/25 1690				○ D 2 L							○
Power lead to room thermostat interrupted (short-circuit)										○	○

① check with test cable

② for checking, remove test cable and reconnect the room thermostat

Check	Remedy
Visual check	Attach or replace hot air hose
Visual check	Remove blockage
Visual check	Remove blockage
Detach cold air hose, measure speed at motor shaft (see p. 3 for check values)	Replace electric motor (see p.21)
Detach cold air hose. If it is possible to turn the shaft of the electric motor:	Replace electric motor (see p.21)
Detach cold air hose. If it is not possible to turn the shaft of the electric motor:	Repair the blower (see p. 22)
Detach the control unit plug, apply positive voltage to terminal 2. If the electric motor does not run:	Replace the P.C.B. (see p. 19)
See under Fault	Replace the P.C.B. (see p. 19)
Switch on the heater, set thermostat from "8" to "1" or detach one connection from temperature control switch. Blower must switch from high to low speed. If it does not run with low speed:	Replace the P.C.B. (see p. 19)
Start the unit at room thermostat setting "1". Electric motor runs at room thermostat setting "8", electric motor does not run at thermostat setting "1"	Replace the P.C.B. (see p. 19)
At setting "8", the metering pump frequency halves when the temperature switch is thrown	Replace the P.C.B. (see p. 19)
Continuity check	Replace operating elements
Continuity check	Replace room thermostat or temperature controller
Carry out measurement at heater plug terminal 2 and 3 (target value 800 Ω - 1.15 K Ω)	Measured value OK: replace room thermostat Measured value not OK: replace sensor in heater
Carry out measurement at heater plug terminal 2 and 3 (target value 800 Ω - 1.15 K Ω)	Interruption: eliminate short-circuit













B 2 L - Version 20 1671 01

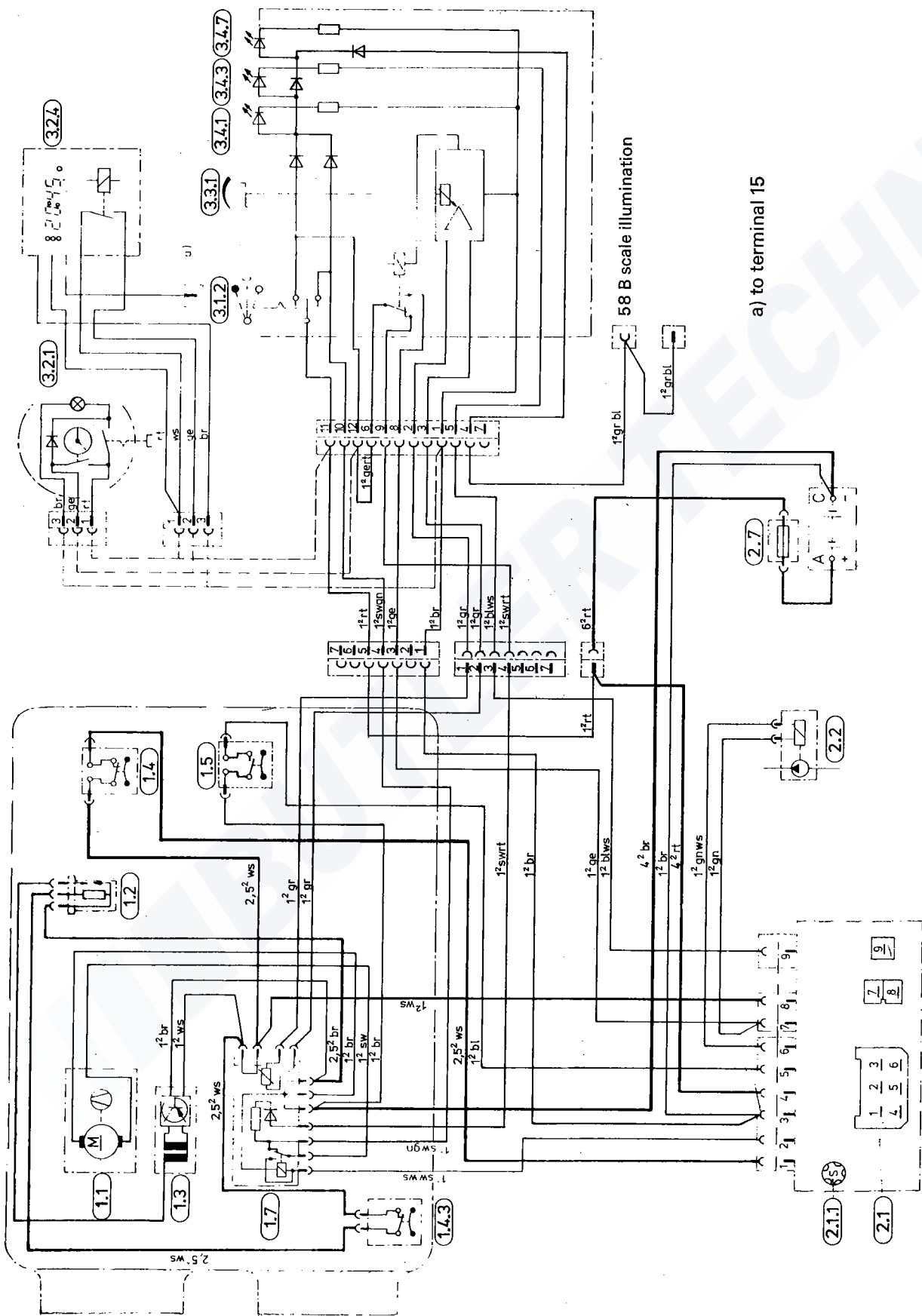

a) to terminal 15

**Parts list**

- 1.1 Blower motor
- 1.2 Glow ignition plug
- 1.3 Ignition spark generator
- 1.4 Temperature switch
- 1.4.3 Heating coil switch
- 1.5 Safety thermal cutout switch
- 1.7 Printed circuit board with room temperature sensor
- 2.1 Control unit
- 2.1.1 Motor fuse
- 2.2 Fuel metering pump
- 2.7 Main fuse 16 A
- 3.1.2 Switch for continuous operation and ventilation
- 3.2.1 Timer
- 3.2.4 Digital timer
- 3.3.1 Room thermostat
- 3.4.1 Operating pilot light green
- 3.4.3 Fault indicator red
- 3.4.7 Illumination

Sp 20 1671 00 96 01

D 2 L - Version 25 1534 01

B 2 L-S - Version 25 1541 01

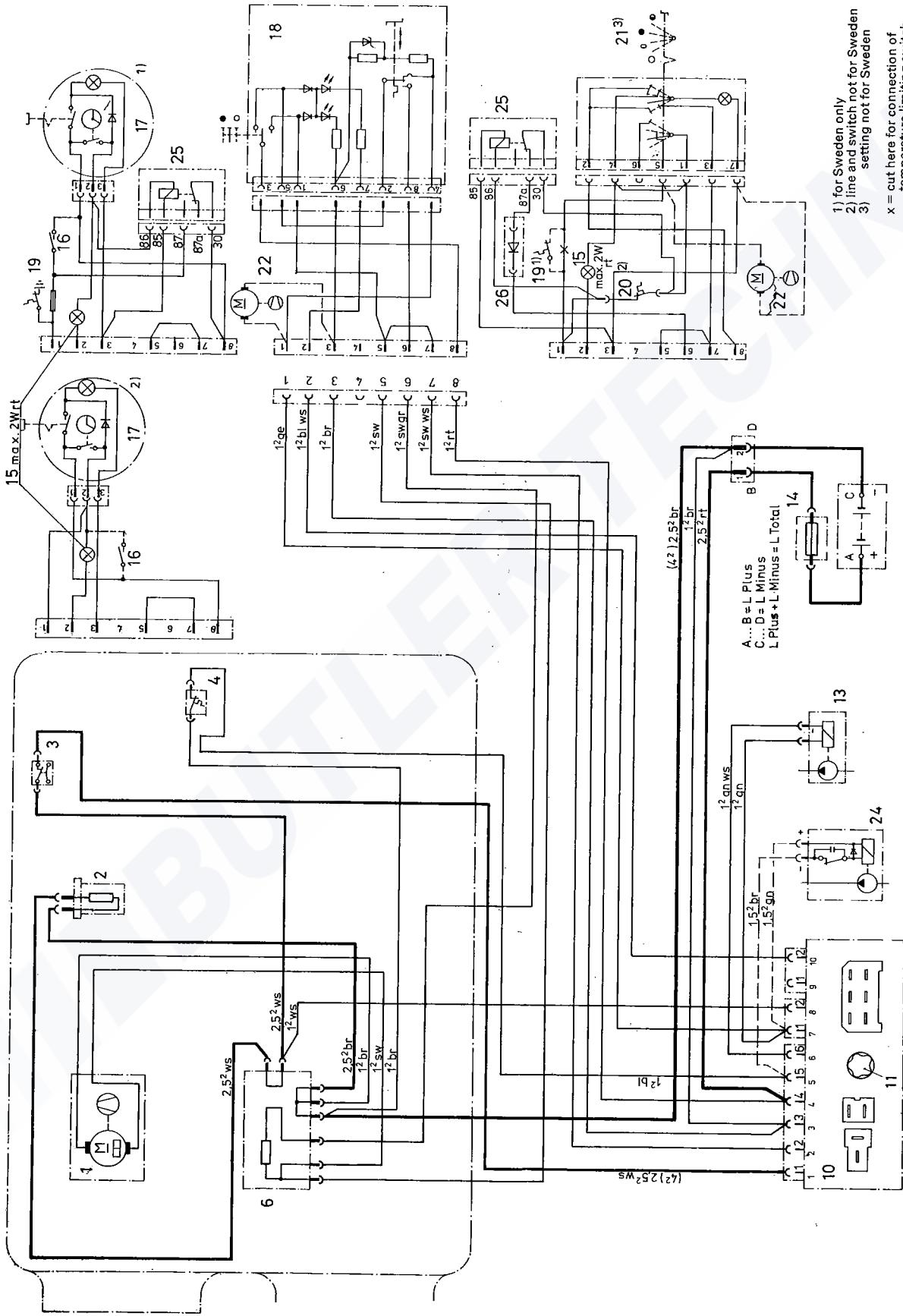

1) for Sweden only  
 2) line and switch not for Sweden  
 3) setting not for Sweden  
 x = cut here for connection of temperature limiting switch

**Parts list**

- |                                |                        |                                    |                                |
|--------------------------------|------------------------|------------------------------------|--------------------------------|
| 1 Blower motor                 | 10 Control unit        | 16 Switch for continuous operation | 21 Universal switch            |
| 2 Glow plug                    | 11 Motor fuse          | 17 Timer                           | 22 Additional blower           |
| 3 Temperature switch           | 13 Fuel metering pump  | 18 Room thermostat                 | 24 Recirculation pump          |
| 4 Safety thermal cutout switch | 14 Main fuse 16 A      | 19 Temperature limiting switch     | 25 Relay } in conjunction with |
| 6 Distributor strip            | 15 Fault indicator red | 20 Temperature control switch      | 26 Diode } item 21             |

25 1507 00 96 01 - G











## Repair instructions

illustrated is heater B 2 L with heating coil switch,  
without room temperature sensor

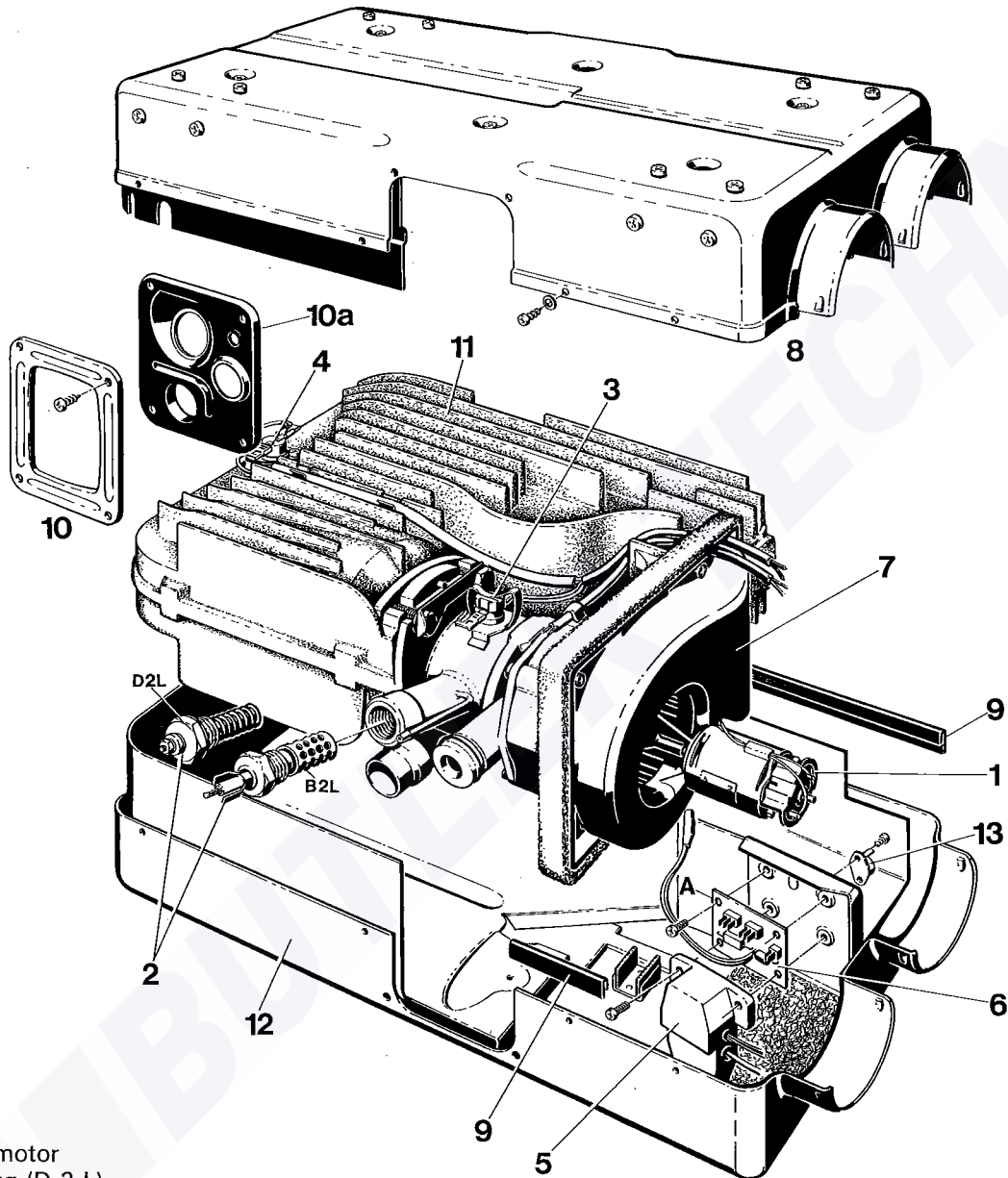

- 1 Electric motor
- 2 Glow plug (D 2 L)
- 3 Glow-ignition plug (B 2 L)
- 4 Temperature switch
- 5 Safety thermal cutout switch
- 6 Ignition spark generator (B 2 L)
- 7 Printed circuit board
- 8 Blower (heating air and combustion air)
- 9 Casing, upper half
- 10 Sealing strips
- 10a Reinforcing plate
- 11 Seal
- 12 Heat exchanger
- 13 Casing, lower half
- 14 Heating coil switch

A Two upper fixing screws only in design 201609 01

### 1. Removing the outer casing

**Removal:** Unscrew the support plate.  
Remove the screws from the outer casing sections and take off the top half.  
Snap the rubber seal out of the top casing half.

**Installation:** Installation is in reverse order.  
See also repair step 10 "Assembling the heater" on p. 23.

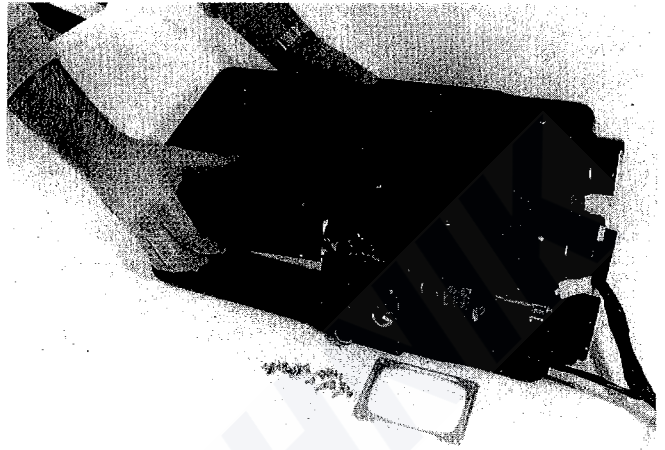

### 2. Removing and installing the printed circuit board

**Removal:** Bend the holding bracket upwards and expose the cable harness. Pull the room temperature sensor out of its holder (20 1661 / 25 1597 / 25 1684 / 25 1690 only). Undo the screws from the ignition spark generator and remove the latter. Detach the cable from the printed circuit board.

**Installation:** Installation is in reverse order.  
**Please note** the cable colours printed on the board and the wiring diagram.  
See also repair step 10 "Assembling the heater" on p. 23.



### 3. Removing and installing the ignition spark generator (B 2 L only)

**Function:** The ignition spark generator supplies, during starting and control operation, the glow ignition plug with the voltage necessary for formation of an ignition spark.

**Removal:** Remove the clip and matching piece from the plug and remove the latter. Detach the plug connector from the glow ignition plug and unscrew the plug connector from the plug cable. Undo the screws from the ignition spark generator. Detach white and brown cables from the printed circuit board. Pull plug cable out of the insulating hose and remove the ignition spark generator.

**Installation:** Installation is in reverse order.  
See also repair step 10 "Assembling the heater" on p. 23.





#### 4. Removing and installing the heating coil switch (B 2 L only)

**Function:** The heating coil switch ensures that the heating coil remains switched off in normal control operation when the ignition sparks are sufficient to form a flame.

**Removal:** Detach the cable from the heating coil switch, undo the screws and remove the heating coil switch (see Fig.).

**Installation:** Installation is in reverse order. See also repair step 10 "Assembling the heater" on p. 23.

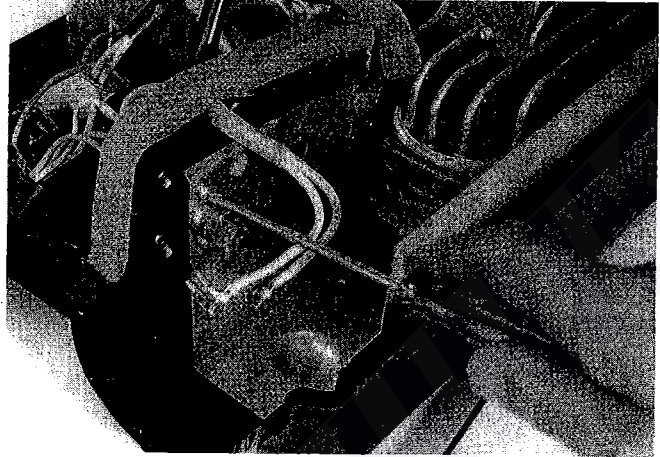

#### 5. Removing and installing the temperature switch

**Function:** The temperature switch turns off the gas plug once a stable flame has been obtained and clears the safety time. Also, it automatically terminates the delayed shutoff once the heater has cooled down.

**Removal:** Detach cable from temperature switch. Unclip the holding spring using a screwdriver. Remove temperature switch, intermediate piece and – if provided – the ring spacer (see illustration).

In the case of the B 2 L, apply some heat conducting paste to the heat exchanger.

**Installation:** Installation is in reverse order. See also repair step 10 "Assembling the heater" on p. 23.

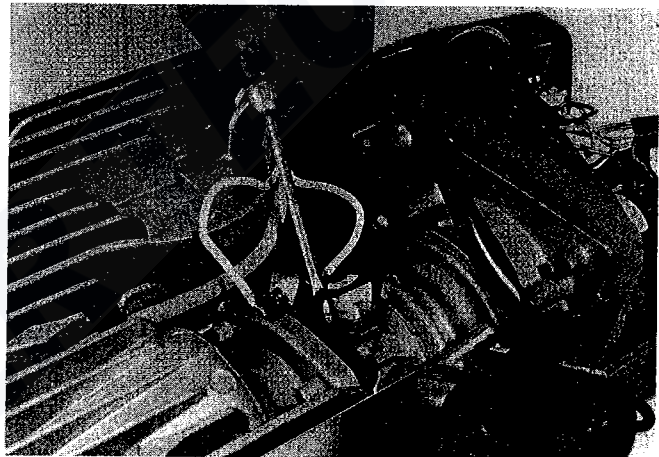

#### 6. Removing and installing the safety thermal cutout switch

**Function:** If the maximum permissible temperature for the heating air is exceeded, the safety thermal cutout switch stops the fuel supply in conjunction with the electronic control unit.

At the same time, the red pilot light in the room thermostat flashes or comes on to show that the heater has overheated.

**Removal:** Detach cable from safety thermal cutout switch, undo the screws and remove the cutout switch, and possibly the grommet and washers (see Fig.).

**Installation: Important:** In the case of the heat exchanger with 2 mm high fastening lugs, a grommet and as many washers as were present in the old switch must be fitted.

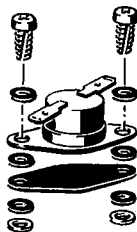
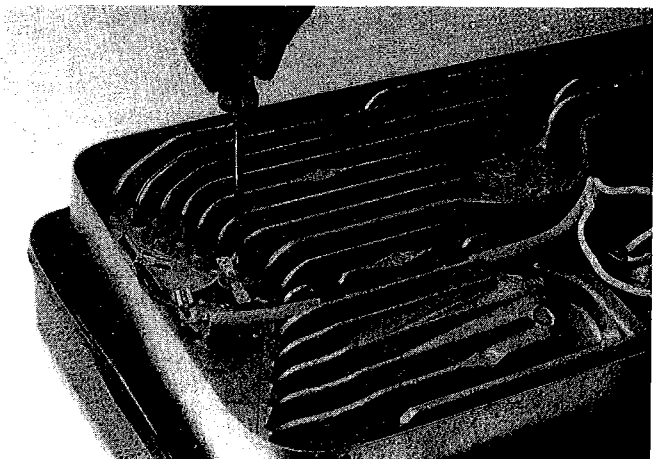

## 7. Removing and installing the electric motor

**Function:** The motor drives the heating air wheel and the combustion air wheel.

**Removal:** Pull room thermostat sensor out of its holder. Detach the brown and black cables from the electric motor at the printed circuit board. Pull heat exchanger, combustion chamber and spiral housing out of the bottom casing half so that all screws are easily accessible. Unscrew the spiral housing from the blower, pull the clutch off the motor shaft, undo the screws from the electric motor and remove the latter. Remove the sealing tape on the spiral housing and remove all grease from the adhesion surface.

**Installation:** When fitting the new motor, take care with the position of the strain relief clamps.

Insert the electric motor and screw it tight. Fit the clutch over the motor shaft, resting the opposite end of the shaft on a support to take the strain off it.

Keep to the dimension of  $4 \text{ mm} \pm 1$  as per sketch 2.

Screw the spiral housing to the blower, ensuring that the grub screw of the blower wheel engages in a recess in the clutch.

Affix a new sealing tape to the spiral housing. Coat the sealing areas of the outer casing halves with Vaseline.

Place the heater in the bottom casing half.

Place the room temperature sensor in its holder.

Connect the brown and black cables to the printed circuit board.

See also repair step 10 "Assembling the heater" on p. 23.

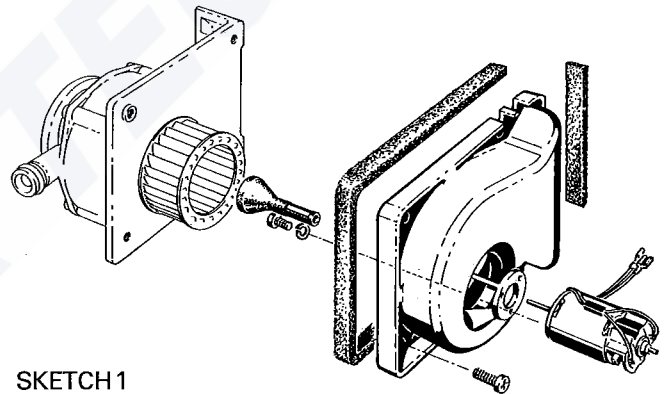
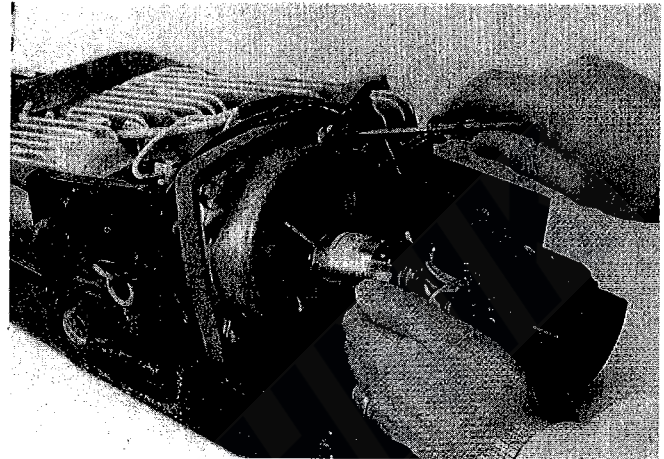

SKETCH 1

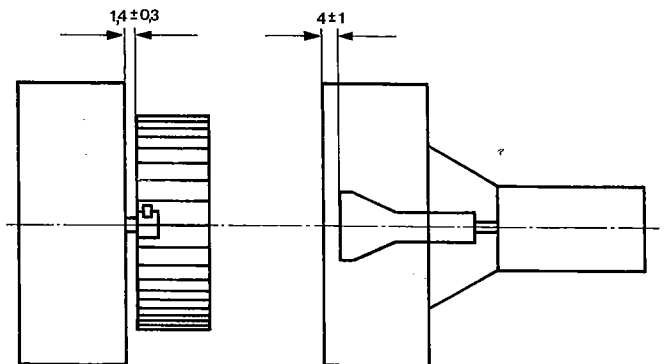

SKETCH 2

Tightening torque of grub screw  $120 \text{ N cm} \pm 30$

## 8. Removing and installing the blower

**Function:** The blower supplies the combustion air required for the combustion process and conveys the heating air – which heats up at the heat exchanger – via the exhauster into the interior of the vehicle.

**Removal:** Pull the room temperature sensor out of its holder. Detach brown and black cables of the electric motor from the printed circuit board.  
Pull heat exchanger, combustion chamber and spiral housing out of the bottom casing half so that the screws of the spiral housing and the screw of the clamping clip are easily accessible. Undo the screws of the spiral housing and remove the latter.  
Undo the screw of the clamping clip, remove the blower from the combustion chamber and take off the sealing ring. Remove the sealing tape on the spiral housing and remove all grease from the adhesion surface.  
If the blower wheel (1) is replaced, keep to the axial dimension of  $1.4 \text{ mm} \pm 0.3 \text{ mm}$  and the grub screw tightening torque of  $120 \text{ N cm} \pm 30 \text{ N cm}$  (see sketch 2).

**Installation:** Fit a new sealing tape on the spiral housing, coating the sealing areas of outer casing halves with Vaseline. Insert a new sealing ring between the blower and the combustion chamber. Fit the blower onto the combustion chamber.  
Fit the clamping clip and tighten it slightly. Screw the spiral housing tight.  
Place the heater in the bottom casing half.  
Place the room temperature sensor in its holder. Connect the brown and black cables from the electric motor to the printed circuit board.  
See also repair step 10 "Assembling the heater" on p. 23.

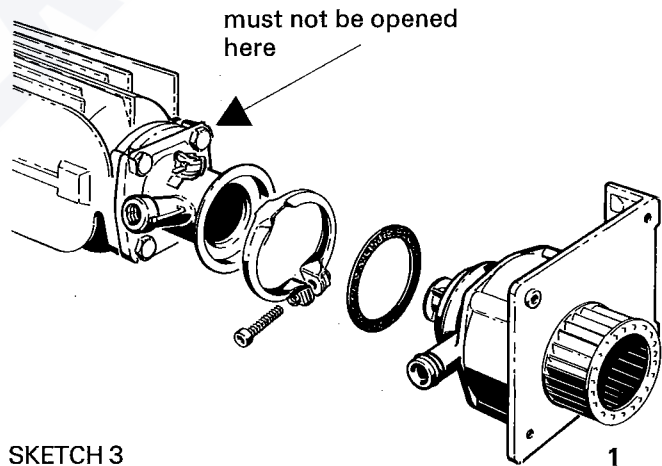
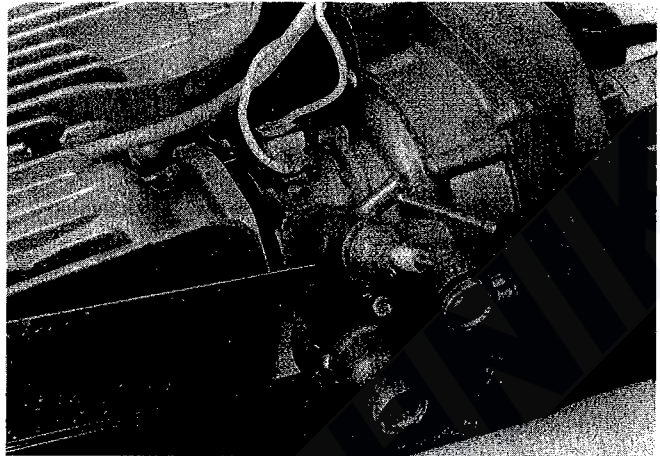



## 9. Removing and installing the heat exchanger with combustion chamber

**Function:** The metering pump conveys a precisely metered quantity of fuel through the plug connection into the combustion chamber, where the fuel combines with the combustion air to form an explosive mixture, which is then ignited by the glow plug. This results in a short time in a stable flame inside the combustion chamber. The hot combustion gases flow through the aluminium heat exchanger connected to the combustion chamber and transmit the heat energy thus generated to the walls of the heat exchanger and are taken up by the heating air flowing through.

**Removal:** Detach the plug connector and plug cable.  
Detach the cable from the safety thermal cutout switch. Detach the cable from the temperature switch.  
Remove the blower (see repair step 8).  
Do not dismantle the heat exchanger and combustion chamber any further.

**Installation:** See repair step 8 on assembling the heat exchanger and blower.  
See repair step 10 on assembling the heater.

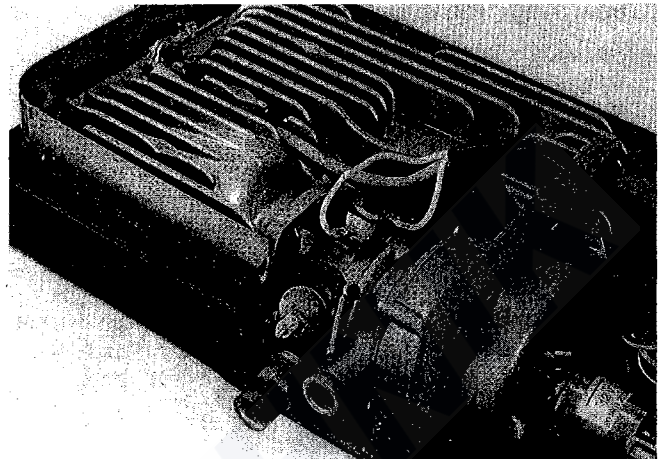

## 10. Assembling the heater

First place the end of the heat exchanger in the bottom casing half, then press the blower down, taking care not to damage the sealing tape on the spiral housing. Tighten the clip between the blower and the heat exchanger, turning the clip so that the screw is next to the exhaust pipe (see also item 8, p. 22).

Attach electrical cables from the electric motor to the printed circuit board (note colours). Place the thermostat, safety thermal cutout switch and plug cables in the recess on the blower and seal them with sealing tape. Slide grommets over the exhaust pipe and the plug and combustion air connections, place them in the lower casing half, and fasten the cable harness to the plug with the locking plate on the housing.

**Important:** Electrical cables must not project above the ribs.

Fit sealing strips on the lower casing half, if necessary coating them with Vaseline. Place the top half of the casing on the bottom half, taking care not to damage the sealing strips. Screw the two casing halves together. Ensure that the grommet on the plug connection is fitted correctly, and screw on the support plate.

## Measuring the fuel quantity

**Important:** Only measure the fuel when the battery charge is sufficient. At least 11 V and no more than 13 V should be applied at the control unit during measurement.

### 1. Preparation

Detach fuel line from the heater and insert it into a measuring glass (10 ml or 25 ml size). Connect a voltmeter to terminal 3 (-) and terminal 4 (+) of the control unit. Prepare a stopwatch. Switch on the heater until fuel is being pumped evenly. The fuel line is now filled and bled. Switch off the heater and empty the measuring glass.

### 2. Measurement

In the case of B 2 L, break the electrical connection at the glow plug, with D 2 L not until the blower is running. Hold the measuring glass at the level of the plug during measurement. Switch on the heater as soon as fuel is being pumped; start the stopwatch, read off the voltage on the voltmeter, and switch the heater back off after 1 minute (or 2 minutes for greater accuracy of measurement). Read off the fuel quantity.

### 3. Evaluation

Using the diagram, read upwards for the voltage measured for the heater model in question, and horizontally to the right from the fuel quantity measured during one or two minutes as the case may be. The intersection of the two lines must be within the two limit curves. If not, replace the metering pump.

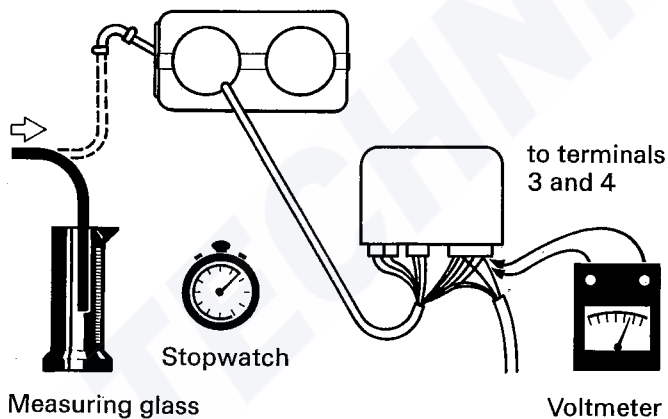

### Diagrams for fuel measurement (in "High" position)

B 2 L 20 1609 01 00 00  
 20 1634 01 00 00  
 20 1661 01 00 00  
 20 1671 01 00 00

D 2 L 25 1534 01 00 00 25 1684 01 00 00  
 25 1597 01 00 00 25 1690 01 00 00  
 25 1632 01 00 00

B 2 L-S 20 1633 01 00 00

D 2 L-S 25 1541 01 00 00

